



water solutions

Data sheet

DRG 400/4/80 H0ET5

GREY
series

Technical specification

3~ 50 Hz

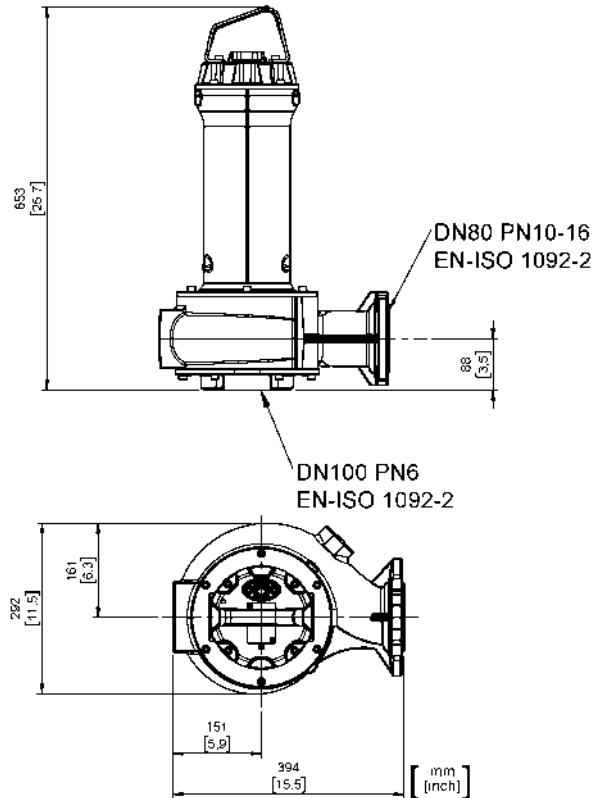
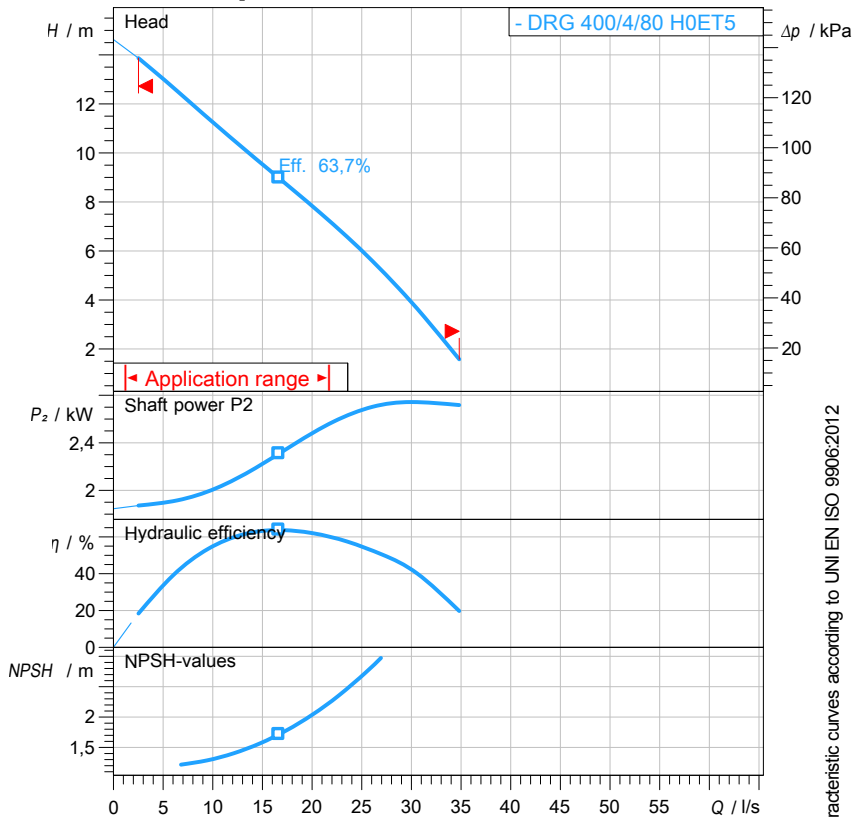

Pump

Series	GREY series
Pump name	DRG 400/4/80 H0ET5
Configuration	NGTAB51040N00NN
Standard	EN 809:2009

Motor data

Rated voltage	400 V
Frequency	50 Hz
Motor phases	3~
Number of poles	4
Rated power P_2	3 kW
Incoming power P_1	3,68 kW
Rated current	6,72 A
rpm	1383 1/min
Efficiency	81,5 %
$\cos \varphi$	0,79
Rated torque	20,7 Nm
Start	Direct starting
Degree of protection	IP 68
Insulation class	H

Hydraulic

Type	DR (Multi-channel open)
Free passage	75 mm
Impeller type	Open channel impeller
Max. hydraulic efficiency	63,7 %
Suction	DN 100 UNDRILLED
Discharge	DN 80 EN 1092-2
Curve tolerance	UNI EN ISO 9906:2012

Operating limits (standard pumps)

Max. ambient temperature	40 °C
Max. density treated liquid	1 100 kg/m ³
Max. immersion depth	20 m
pH treated liquid	6 ÷ 14
Max. start per hour (equally distributed)	30
Wet/dry use	WET
Max. acoustic pressure level	70 dB
Operating mode	S1 - Continuous use

Construction materials

Case	Cast iron EN-GJL 250
Shaft	Stainless steel - AISI 431
Hydraulic	Cast iron EN-GJL 250
Impeller	Cast iron EN-GJL 250
Painting/Coating	Bi-epoxy 150 μ m
Screws	Stainless steel - Class A2-70
Gaskets	NBR

Construction features

Cooling system	No cooling jacket
Main cable	4G1,5 + 3x1
Cable length	10 mt
Mechanical seals	2 in silicon carbide (2SiC)
Additional drilling	-
Weight*	77 kg
Electrical variant	Thermal protection

* cable, stand and guiding system excluded

Rev. 0 - 16-12-2014

All data shown are not binding. Zenit reserves the right to change data and dimensions without notice.

Created on 2018-03-29



water solutions

Data sheet DRG 400/4/80 H0ET5

GREY
series

Pump performance curves

3~ 50 Hz

Hydraulic type DR (Multi-channel open)		Impeller type Open channel impeller		Free passage 75 mm	Discharge DN 80	Suction DN 100
DUTY POINT						
Flow	Head	Shaft power P2	Hydraulic efficiency	Density 998,3 kg/m ³	Viscosity 1,005 mm ² /s	

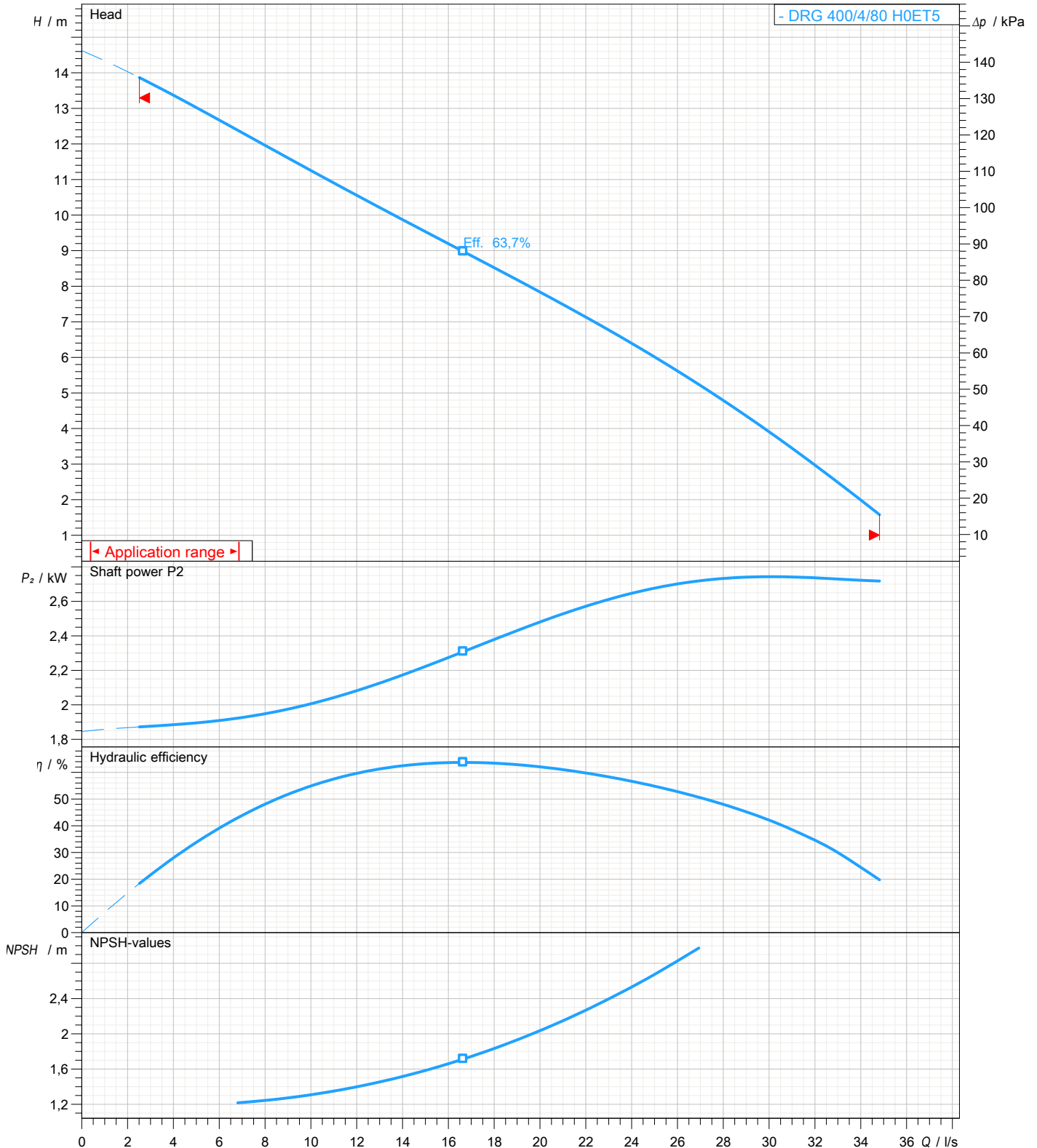

Characteristic curves according to UNI EN ISO 9906:2012



water solutions

Data sheet DRG 400/4/80 H0ET5

GREY
series

Dimensional drawing

3~ 50 Hz

Installation type Installation with bottom coupling device - Vertical outlet		
Wet/dry use WET	Drilling variant N	Flushing valve - drilling -
Discharge DN 80 EN 1092-2	Suction: DN 100 UNDRILLED	Pressure rating (suction/discharge) -/PN 10
Accessory DAC 80/80V+KAF 116-2" EN (P)		Accessory code 9001.032
Note: Accessory must be ordered separately		

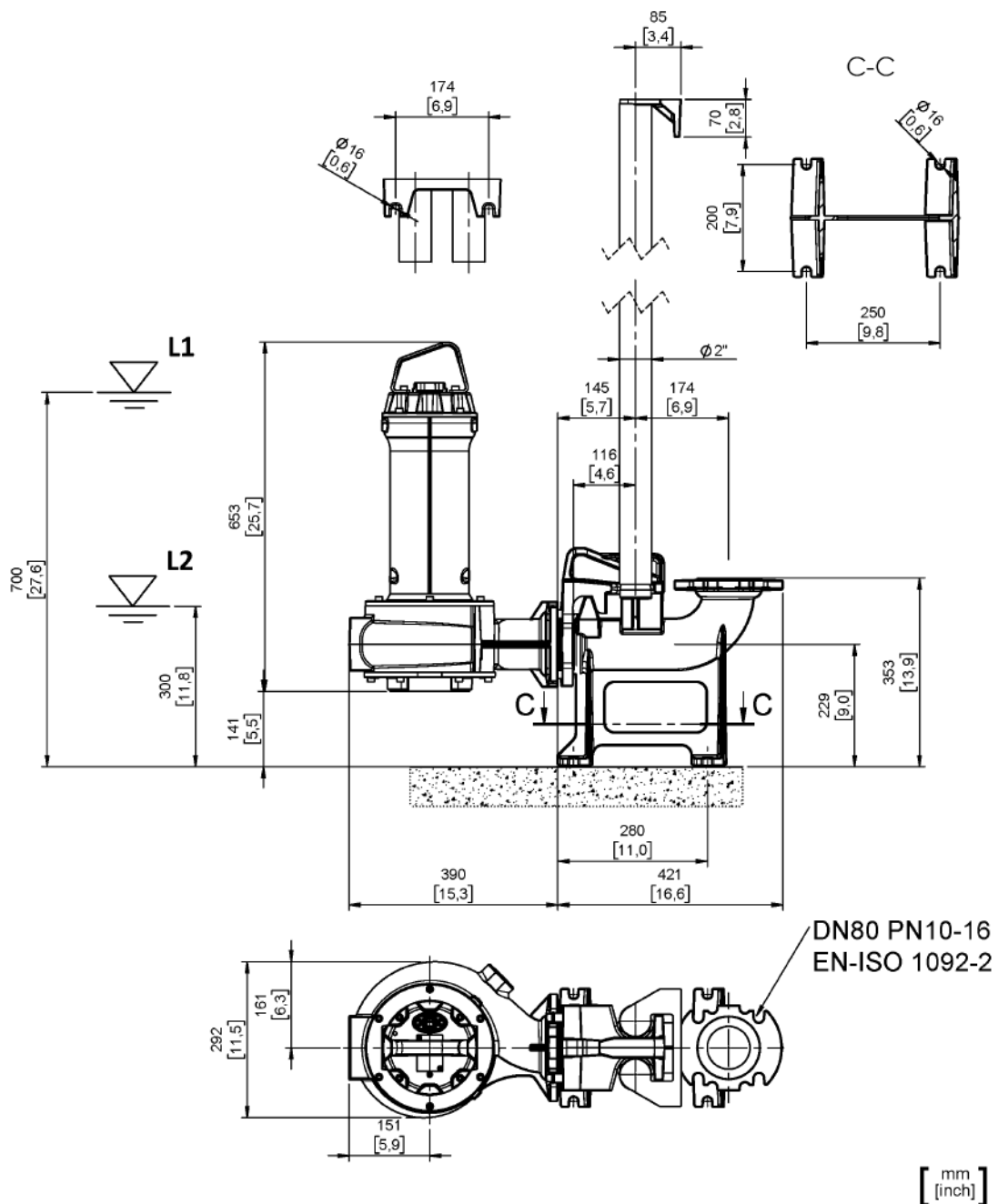

L1: Minimum operating level for continuous use

L2: Minimum operating level for discontinuous use (only "WET" version)